

PORTE GRAND TRAFIC A L'ANGLAISE ANTI-PINCE DOIGT DE NIVEAU 2
1 VANTAIL ET 2 VANTAUX

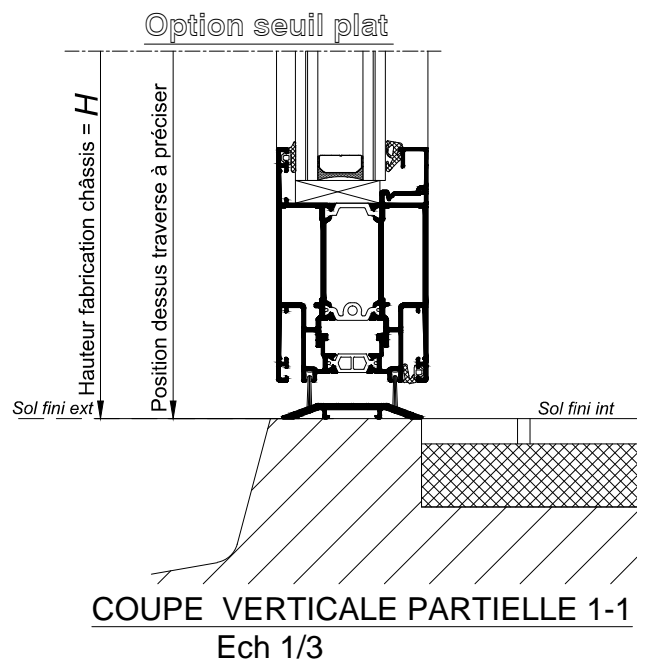

PORTE GRAND TRAFIC A L'ANGLAISE ANTI-PINCE DOIGT DE NIVEAU 2
1 VANTAIL ET 2 VANTAUX

1 Vantail

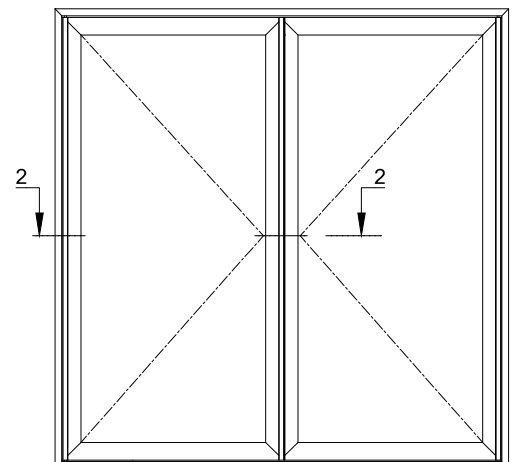
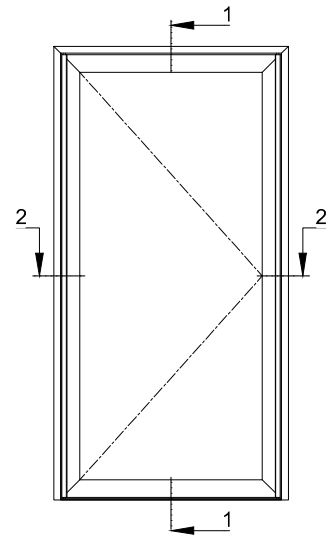
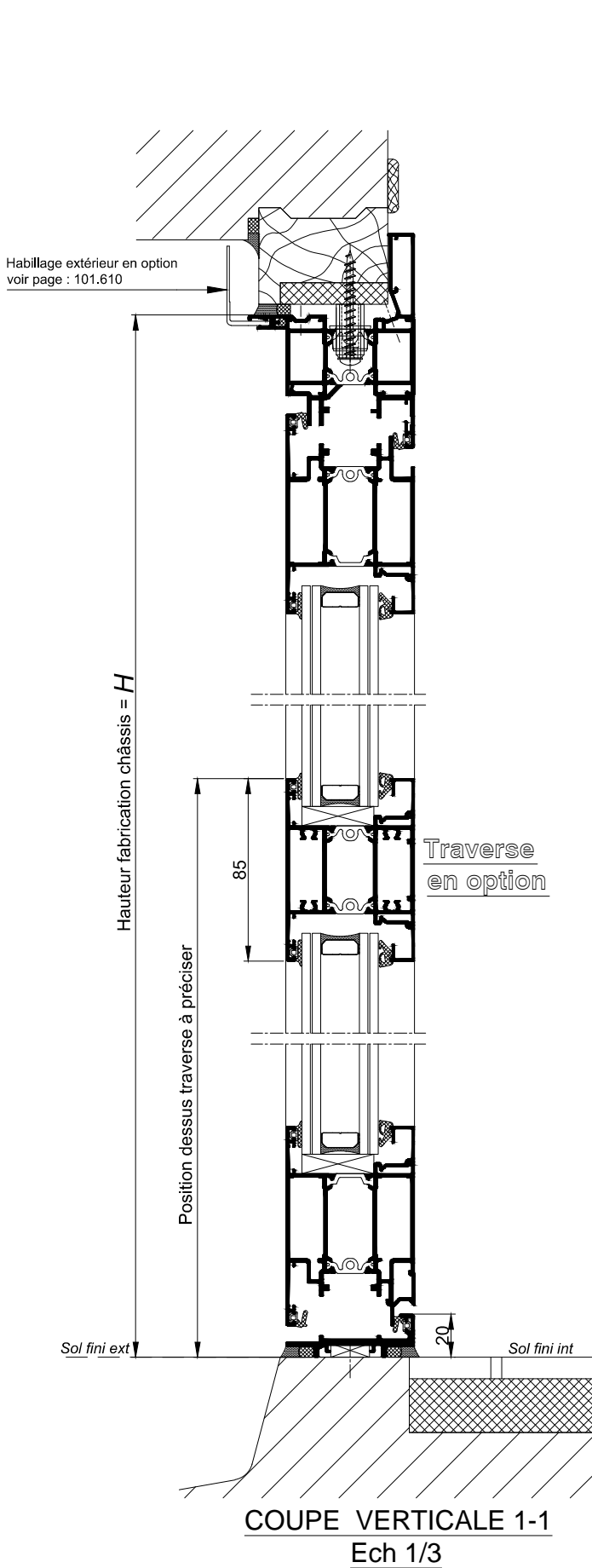
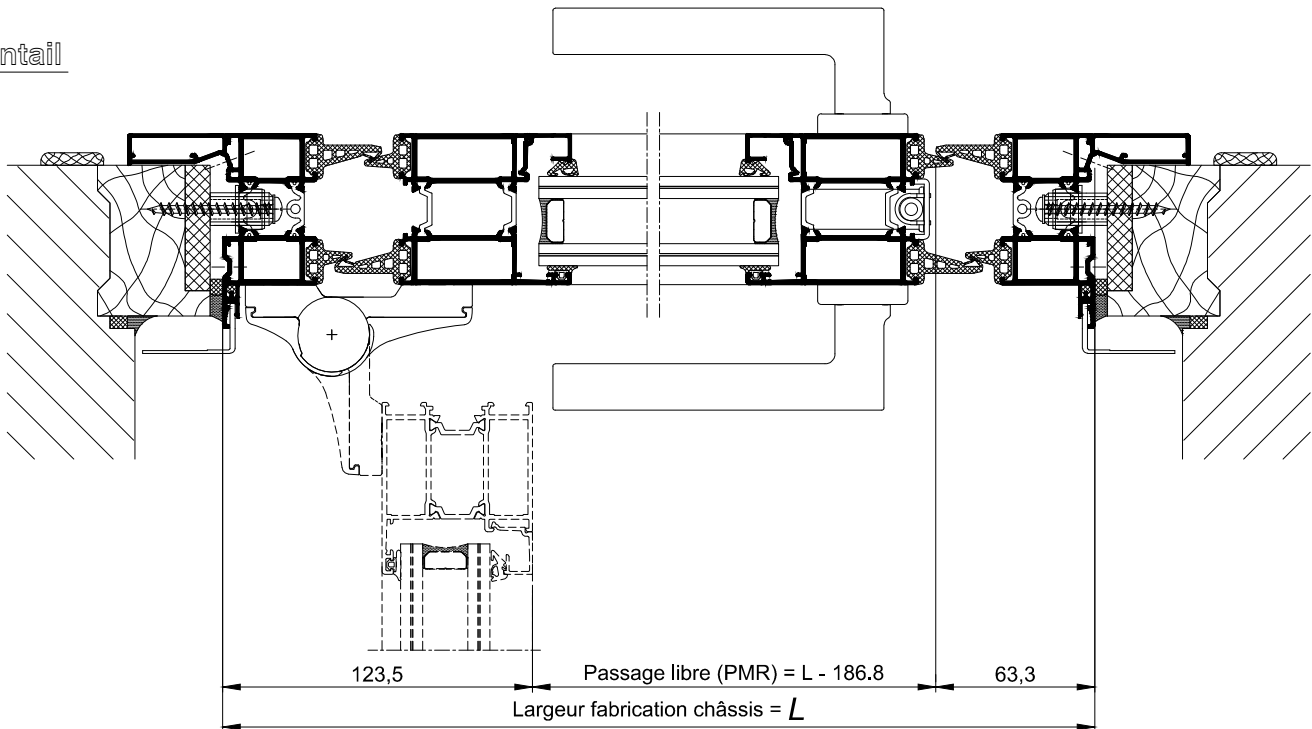

COUPE HORIZONTALE 2-2

Ech 1/3

2 Vantaux

(L1 = L/2 si 2 vantaux égaux)

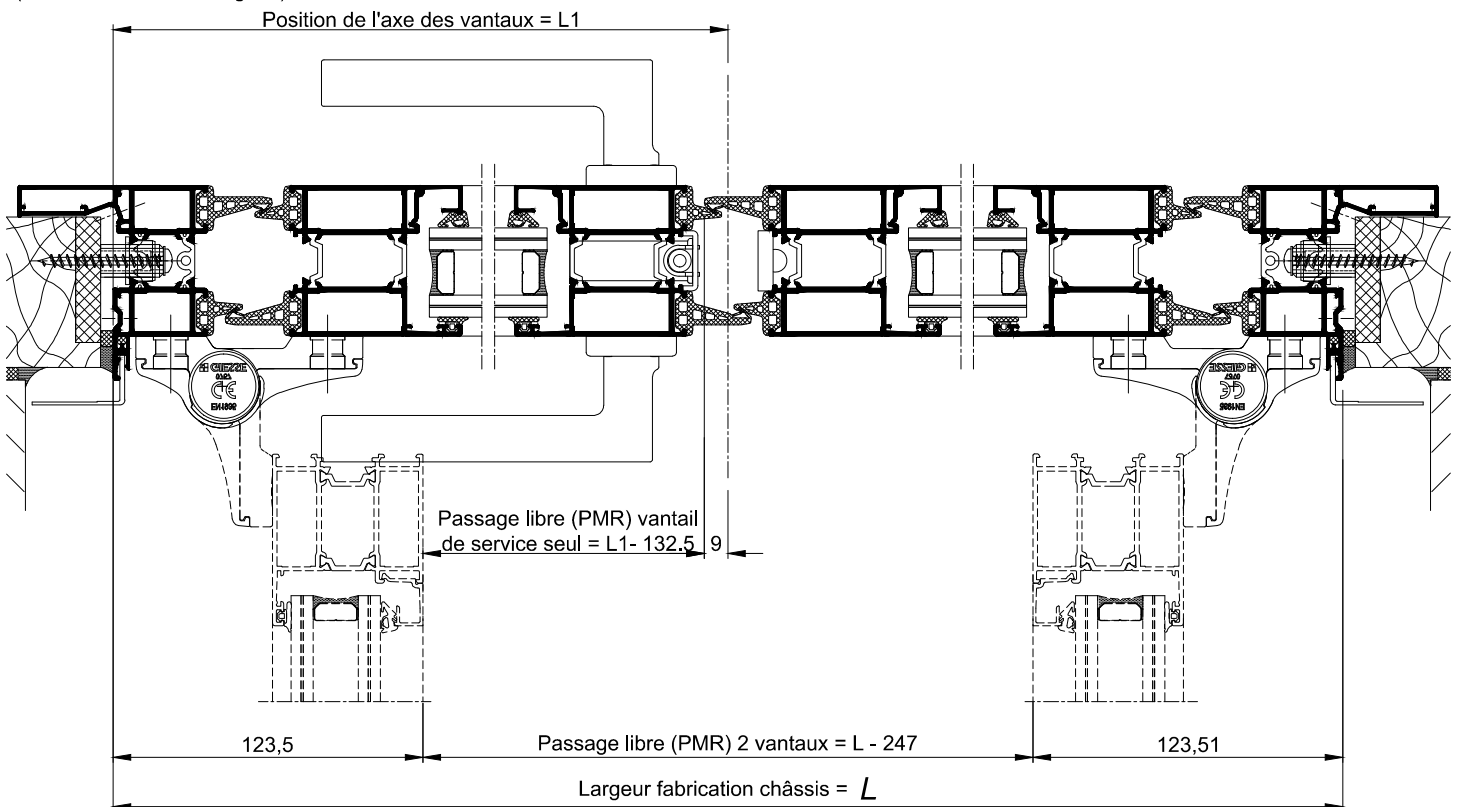

COUPE HORIZONTALE 3-3

Ech 1/3