

COUPE VERTICALE 1-1
Ech 1/3

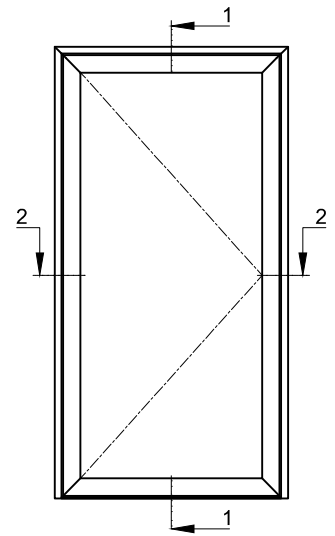

NOTA: Le seuil plat est réservé
aux portes protégées de la pluie
suivant DTU 36.5

Option seuil plat

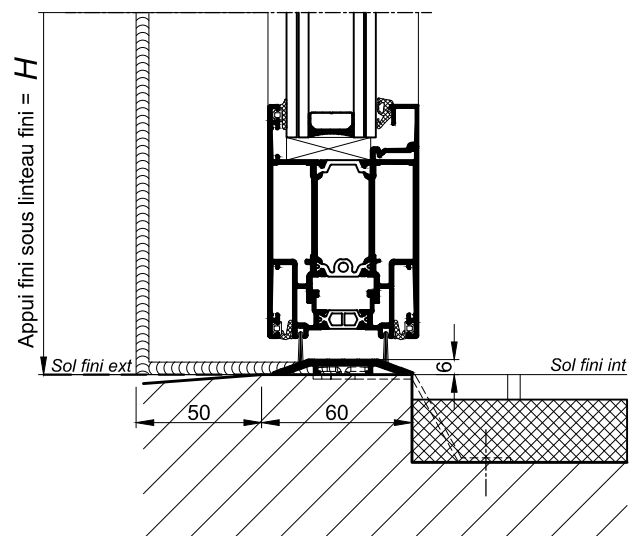

COUPE VERTICALE PARTIELLE 1-1
Ech 1/3

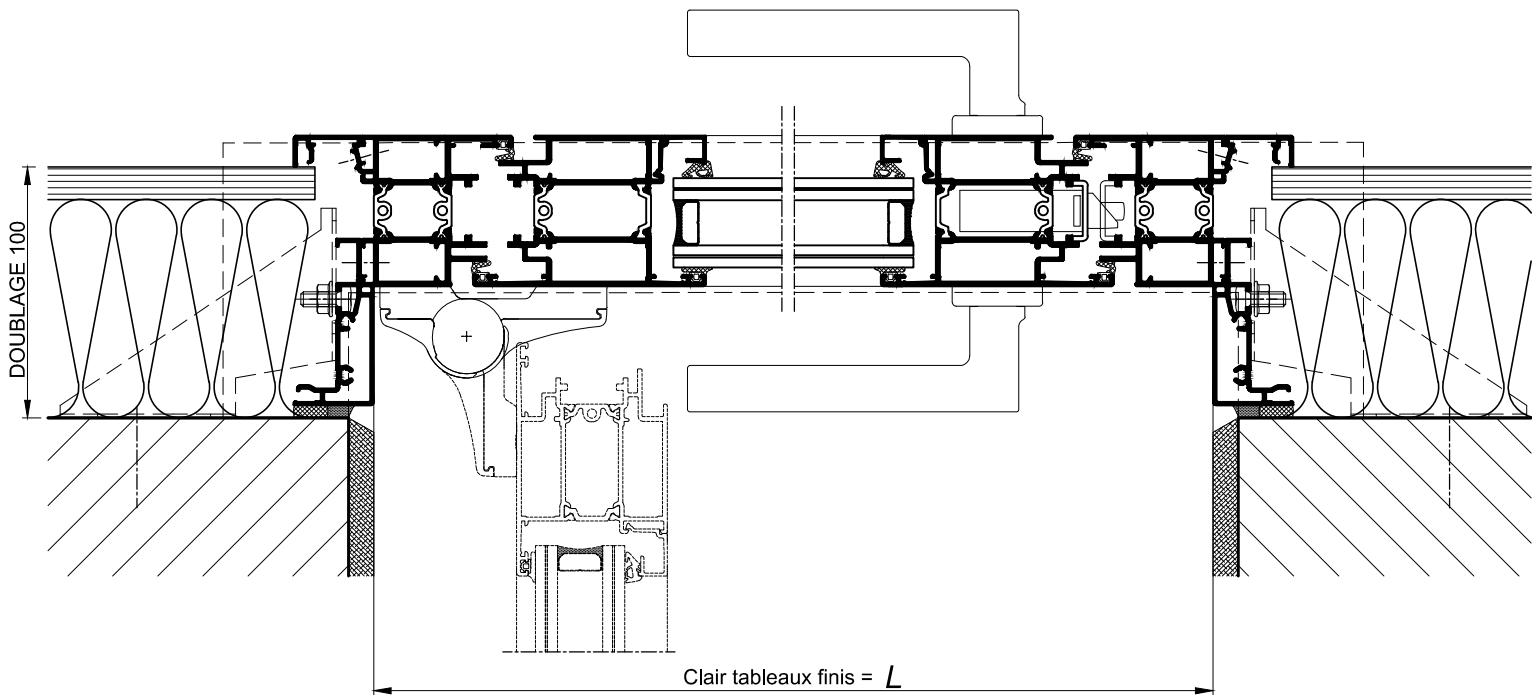

COUPE HORIZONTALE 2-2
Ech 1/3